



Requirement class IIIA, EN 574 P1HZ X1



Two-hand control device for safety circuits

Approvals

	P1HZ X1
	◆
	◆
	◆

Unit features

- ▶ Positive-guided relay outputs:
 - 2 safety contacts (N/O), instantaneous
- ▶ Connection options for:
 - 2 operator elements (buttons)
- ▶ LED indicator for:
 - Switch status channel 1/2
 - Supply voltage

Unit description

The two-hand control relay meets the requirements of EN 574 Type IIIA. It forces the operator to keep his hands outside the danger zone area during the hazardous movement. It is designed for use in two-hand circuits.

Caution!

The two-hand control relay may **not** be used on **press controllers**. It is only suitable for use where the risk analysis has established a low level of risk (e.g. EN 954-1 Cat. B or 1).

Safety features

The two-hand control relay meets the following safety requirements:

- ▶ The two-hand control relay prevents the plant from being enabled in the following cases:
 - Power supply failure
 - Component failure
 - Short circuit on an input circuit
 - Coil defect
 - Open circuit
 - Earth fault
- ▶ In each on-off cycle, the output relays on the safety device are tested to ensure they open and close correctly

Block diagram

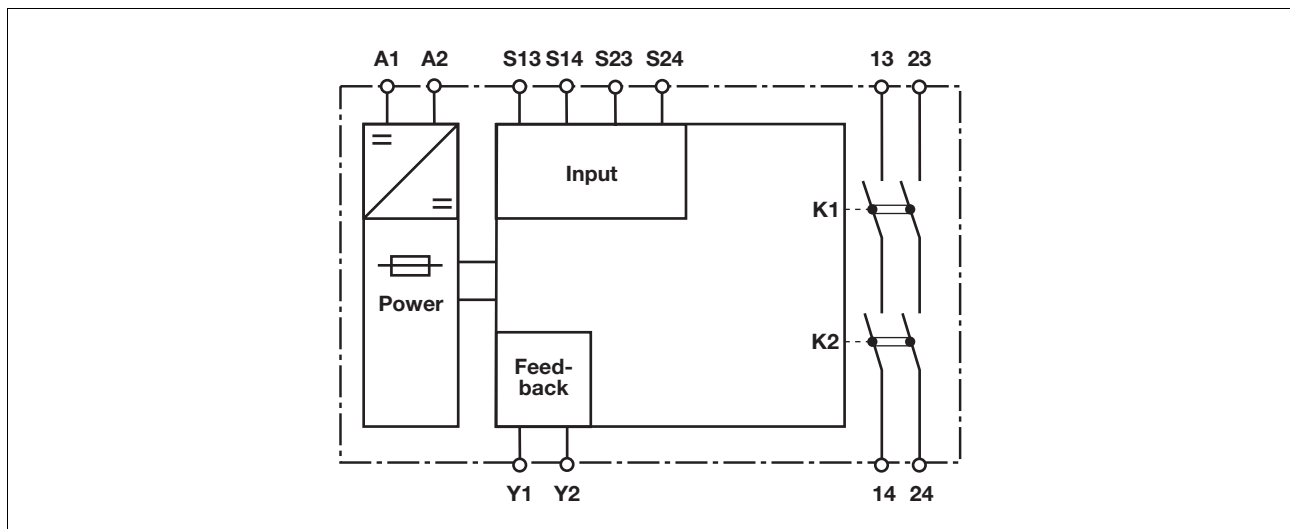

Requirement class IIIA, EN 574 P1HZ X1

Function description

- ▶ The two-hand control relay must be activated by simultaneously pressing two buttons. If one or both of the buttons are released, the unit interrupts the control command for the hazardous movement.
- ▶ Reactivation: The output relays will not re-energise until both operator elements have been released and then re-operated simultaneously.
- ▶ Increase in the number of available contacts by connecting contact expander modules or external contactors/relays.

Timing diagram

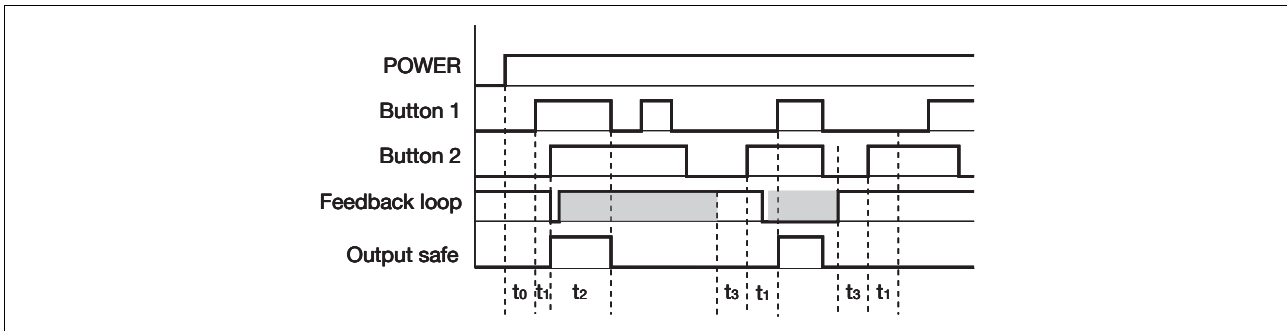

Key

- ▶ POWER: Supply voltage
- ▶ Button 1/Button 2: Input circuits S13-S14, S23-S24
- ▶ Feedback loop: Feedback loop Y1-Y2
- ▶ Output safe: Safety outputs 13-14, 23-24
- ▶ t₀: Recovery time after power on
- ▶ t₁: Simultaneity, channel 1 and 2
- ▶ t₂: Operating cycle ended through button 1 or 2
- ▶ t₃: Y1-Y2 must be closed before before the button is operated (recovery time)
- ▶ Shaded area: Status irrelevant

Wiring

Please note:

- ▶ Information given in the “Technical details” must be followed.
- ▶ Outputs 13-14, 23-24 are safety contacts.
- ▶ To prevent contact welding, a fuse should be connected before the output contacts (see technical details).
- ▶ Calculation of the max. cable runs I_{max} in the input circuit:

$$I_{max} = \frac{R_{lmax}}{R_l / km}$$

R_{lmax} = max. overall cable resistance (see technical details)

R_l / km = cable resistance/km

- ▶ Use copper wire that can withstand 60/75 °C.
- ▶ Sufficient fuse protection must be provided on all output contacts with capacitive and inductive loads.

Requirement class IIIA, EN 574 P1HZ X1

Preparing for operation

▶ Supply voltage

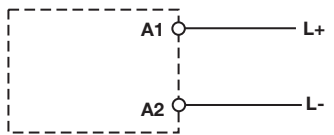
Supply voltage	AC	DC
		

▶ Input circuit

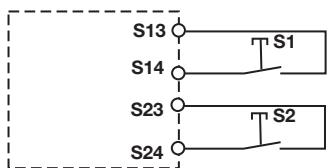
Input circuit	Single-channel	Dual-channel
Two-hand button with detection of shorts across contacts		

▶ Feedback loop

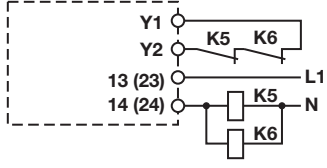
Feedback loop	
Contacts from external contactors	

▶ Key

S1/S2	Two-hand button
-------	-----------------

Requirement class IIIA, EN 574

P1HZ X1

Terminal configuration

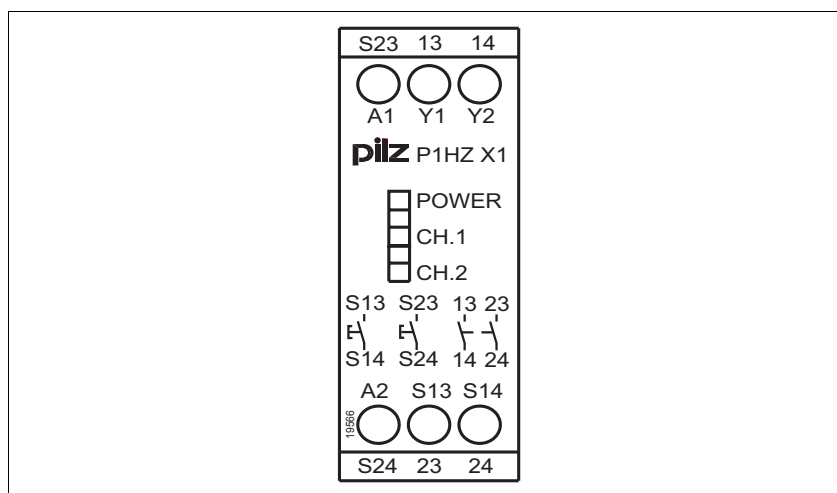

Installation

- ▶ The safety relay should be installed in a control cabinet with a protection type of at least IP54.
- ▶ Use the notch on the rear of the unit to attach it to a DIN rail.
- ▶ Ensure the unit is mounted securely on a vertical DIN rail (35 mm) by using a fixing element (e.g. retaining bracket or an end angle).

Notice

The distance of the button connected to the two-hand relay from the nearest danger zone must be large enough that if one of the buttons is released, the dangerous moment is interrupted before the operator can reach into the danger zone (see EN 999 "The positioning of protective equipment in respect of approach speeds of parts of the human body").

Dimensions

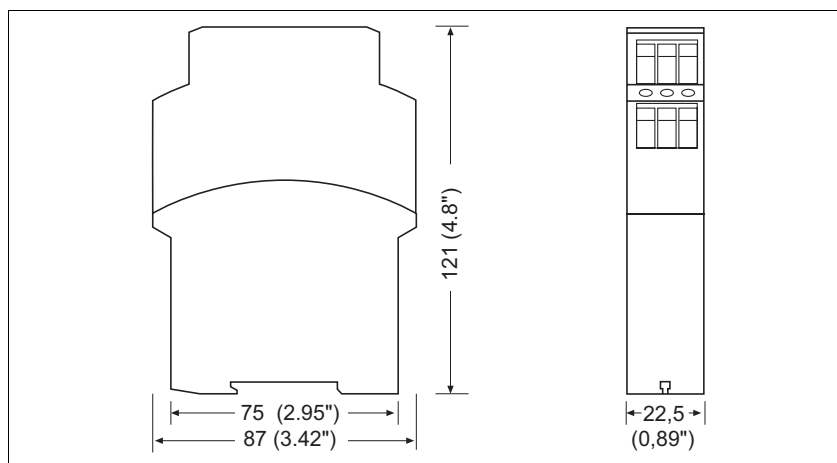

Requirement class IIIA, EN 574 P1HZ X1

Notice

This data sheet is only intended for use during configuration. For installation and operation, please refer to the operating instructions supplied with the unit.

Service life graph

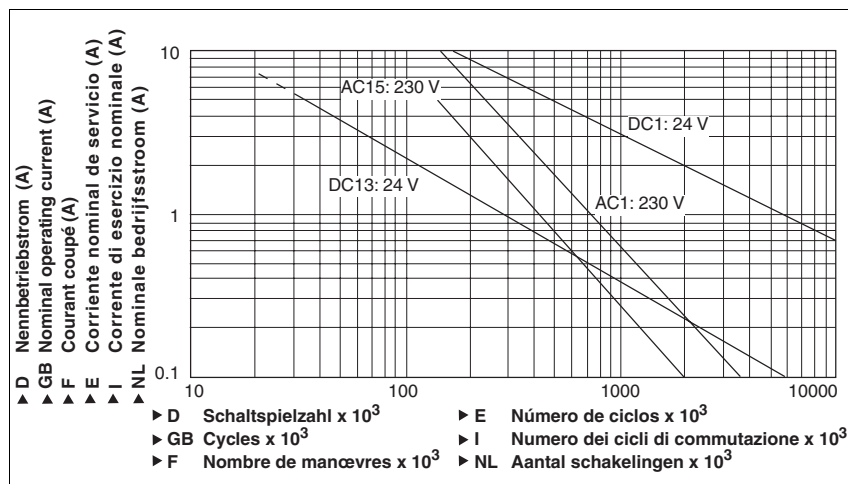

Technical details

Electrical data

Supply voltage U_B DC	24 V
Voltage tolerance	-15 % / 10 %
Power consumption at U_B DC	2.0 W
Residual ripple DC	10 %
Voltage and current at input circuit: 24 VDC	
N/O contact	10 mA
feedback loop: 24 VDC	40.0 mA
Output contacts in accordance with EN 954-1 , Category 1	Safety contacts (N/O): 2
Utilisation category in accordance with EN 60947-4-1 AC1: 240 V	$I_{min}: 0.01 \text{ A}, I_{max}: 6.0 \text{ A}$ $P_{max}: 1500 \text{ VA}$
DC1: 24 V	$I_{min}: 0.01 \text{ A}, I_{max}: 6.0 \text{ A}$ $P_{max}: 150 \text{ W}$
Utilisation category in accordance with EN 60947-5-1 AC15: 230 V DC13 (6 cycles/min): 24 V	$I_{max}: 5.0 \text{ A}$ $I_{max}: 2.5 \text{ A}$
Contact material	AgSnO₂ + 0.2 μm Au
External contact fuse protection (EN 60947-5-1)	
Blow-out fuse, quick	6 A
Blow-out fuse, slow	4 A
Circuit breaker	4 A, 24 VAC/DC, characteristic B/C
Max. overall cable resistance R_{lmax} per input circuit,	14 Ohm
Times	
Delay-on de-energisation (reaction time in accordance with EN 574)	
N/O contact	15 ms
Recovery time after two-hand	150 ms
Simultaneity, channel 1 and 2	500 ms
Environmental data	
EMC	EN 60947-5-1, EN 61000-6-2
Vibration in accordance with EN 60068-2-6	
Frequency	10 - 55 Hz
Amplitude	0.35 mm
Climatic suitability	EN 60068-2-78
Airgap creepage	VDE 0110-1

Requirement class IIIA, EN 574 P1HZ X1

Environmental data	
Ambient temperature	-10 - 55 °C
Storage temperature	-25 - 85 °C
Protection type	
Mounting (e.g. cabinet)	IP54
Housing	IP40
Terminals	IP20
Mechanical data	
Housing material	
Housing	PPO UL 94 V0
Front	ABS UL 94 V0
Max. cross section of external conductors with screw terminals	
1 core flexible	0.20 – 4.00 mm ²
2 core, same cross section, flexible:	
with crimp connectors, without insulating sleeve	0.20 – 2.50 mm ²
without crimp connectors or with TWIN crimp connectors	0.20 – 2.50 mm ²
Torque setting with screw terminals	0.60 Nm
Dimensions (H x W x D)	
with screw terminals	87.0 mm x 22.5 mm x 121.0 mm
Weight	210 g

The standards current on **08/02** apply.

Order reference			
Type	Features	Terminals	Order no.
P1HZ X1	24 VDC	Screw terminals	774 360